

# Simulation of Heat Transfer of Defective Copper Stave with Installing Flexible Pipe or Cigar Cooler

CHUNG-KEN HO\*, YOU-ZONG CHEN\*\* and CHE-HSIUNG TUNG\*\*\*

*\*Iron and Steel Research & Development Department  
China Steel Corporation*

*\*\*Vehicle Engineering Department  
National Pingtung University of Science and Technology*

*\*\*\*Ironmaking Department  
China Steel Corporation*

The No. 2 blast furnace (BF) at China Steel (CSC) installed a copper stave for the first time in its new campaign of January 2006. Unfortunately, the copper stave channel showed leakage at the lower shaft in September 2011. For maintaining the stave, the flexible pipe and cigar cooler are installed depending on the damage extent. In this study, the heat transfer behavior of a defective copper stave with installing flexible pipe or cigar cooler has been analyzed. Compared with measured data from copper stave with label S9-33 at No. 2 BF during stable operation, the hot gas temperature is inferred about 400 °C. The cooling ability of 4 flexible pipes with low thermal conductivity 1.5 W/m/°C is not sufficient during stable operation. The grouting materials with high thermal conductivity 15 W/m/°C is preferred and suggested. The defective copper stave with 24 cigar coolers is acceptable during stable operation. However, the shell temperatures in cigar cooler case are larger than 200 °C with any kinds of grouting material, when the hot gas temperature is 1200 °C. In the mean time, to control the hot gas temperature becomes very important to protect the furnace shell of a copper stave with 24 cigar coolers.

**Keywords:** Blast furnace, Copper stave, Flexible pipe, Cigar cooler

## 1. INTRODUCTION

Since 1884, a cooling plate attached on blast furnace shell from tuyere to throat has been applied to protect the shell and to prolong the blast furnace campaign life. Around 1970, a new cooling system, a cast iron stave, was developed by the USSR suppliers. However, the cast iron stave has been shown to develop abrasions after a blast furnace operation of about 7 years, coupled with a high susceptibility to cracking under the severe heat load and temperature fluctuations. In 1979, the two copper staves were installed for testing at No. 4 BF of Thyssen Hamborn and the wear on the copper stave during a 10-year campaign has been insignificant<sup>(1)</sup>. Since 2000, many blast furnace operators have installed copper staves at the bosh, belly and lower shaft areas to extend the life of the cooling system to one campaign.

A cast iron stave was first installed in No. 3 BF of CSC in January 2000 to increase the working volume with same shell dimensions and to ensure a smooth burden descent. The leakage from the cast iron stave in

the belly area of No. 3 BF was first found in April 2008. To extend the life of the cooling system to one campaign of about 15 years, copper staves were introduced into the bosh, belly and lower shaft areas of No.2 BF in January 2006, and of No. 1 BF in June 2010, respectively. Unfortunately, a copper stave channel leakage occurred in the lower shaft of No. 2 BF in September 2011, and in the bosh area of No. 1 BF in November 2011. To protect the furnace shell, a small metal flexible pipe is first inserted into the channel when a channel leakage is found. For even more serious cases, a cigar cooler is inserted into the copper stave from the furnace shell after the flexible pipe has been eroded away, and then is plugged with grouting material.

Several 3-D mathematical models have been employed to investigate the heat transfer of stave coolers, including cast iron staves and copper staves<sup>(2,3)</sup>. The accretion thickness and temperature of the hot surface of a copper stave were also studied to understand its effect on stave temperature<sup>(4,5)</sup>. To predict the lining thickness of copper stave, a 3-D domain of a copper

stave including a sensor bar in a computational fluid dynamics (CFD) model was established in No. 1 BF of CSC<sup>(6)</sup>. However, the stave temperature was not determined after the copper stave channel leakage. In this study, the heat transfer of a defective copper stave with a flexible pipe installed or with a cigar cooler installed are simulated to evaluate the stave and shell temperature.

## 2. PHYSICAL SYSTEM

Figure 1 presents a schematic copper stave in good condition. The copper stave is composed of a furnace shell, a packing layer, the stave body, four water channels, a rib, refractory bricks, and the lining material. After the rib and refractory brick are eroded, the water in the channel will flow into the furnace causing a severely chilled hearth. The two kinds of physical systems to rectify this leakage are described in the following sub-sections.

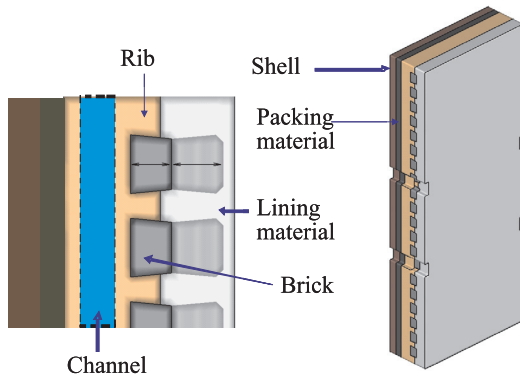
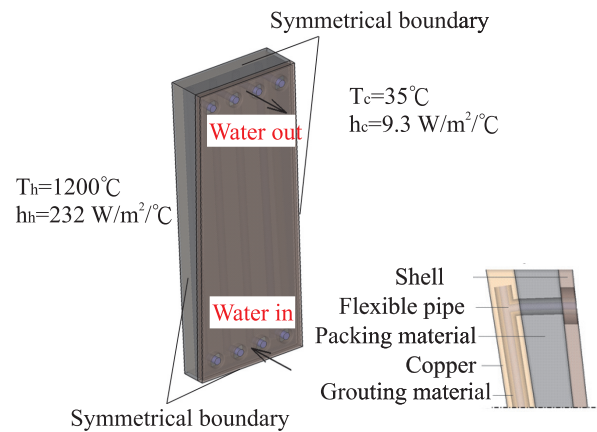

**Fig.1.** A schematic copper stave in good condition.

### 2.1 Flexible pipe

Once a channel leakage is found, a metal flexible pipe which is smaller than the channel is penetrated into the channel to replace the function of the defective channel. A grouting material is then pumped into the gap between the pipe and the channel to increase the repaired copper stave's cooling ability. It is assumed that the copper material positioned around the channel opening has gone. In order to adapt to this condition, the rib, the brick, and the lining material are removed from the simulation domain. Figure 2 shows the typical boundary conditions of the copper stave and flexible

pipe. In general, the hot face of copper stave is intermittently in contact with coke, reduced sinter, melt, and hot gas. To simplify the simulation, the hot gas was only used to balance the temperature in this study due to the indistinguishable complexity and uncertainty in a blast furnace. The thermal conductivity of the materials used in the present system are listed in Table 1. To explore the possible conditions, four differently-designed flexible pipes are shown in Fig.3.



**Fig.2.** The typical boundary conditions of a copper stave with flexible pipe.

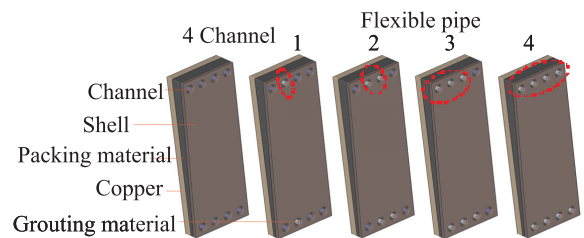

**Fig.3.** A copper stave with different arrangements of flexible pipe.

### 2.2 Cigar cooler

Having been eroded and caused water again to leak into the furnace, the flexible pipe will be plugged with grouting material during blow-down. The other way to protect the shell is to insert a cigar cooler into the copper stave from furnace shell. Figure 4 schematically displays a defective copper stave with 24 cigar coolers and the boundary conditions for the

**Table 1** Thermal conductivity of materials

Material	Shell	Copper	Packing material			Grouting
			400 °C	800 °C	1200 °C	
Thermal conductivity (W/m/°C)	52.2-0.025 T	387.6	1.90	1.54	1.5	1.5

subsequent simulation. The effect of distance between two cigar coolers on the shell temperature was investigated in this model. To shorten the computation time, half a copper stove with 12 cigar coolers was set as the domain.

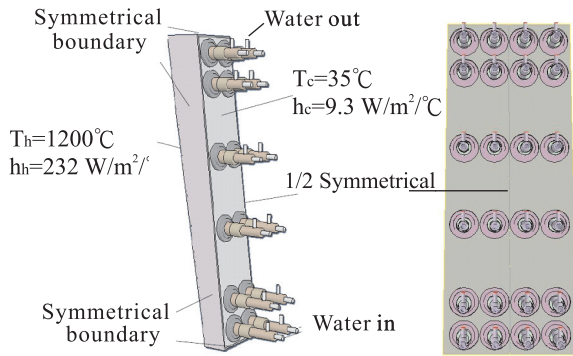

**Fig.4.** A defective copper stove with 24 cigar coolers and boundary conditions.

### 3. MATHEMATICAL MODEL

Figures 2, 3 and 4 depict the system to be analyzed. The whole system is considered as a conjugate system with the water running through channel, flexible pipe or cigar cooler, along with the heat conduction in the furnace shell, packing material and copper, together with the thermal radiation and convection from the furnace gas to copper hot face. The governing equations and solution methods have been described in the previous paper<sup>(6)</sup>.

### 4. RESULTS AND DISCUSSIONS

#### 4.1 Copper stove with channel

Based on an inlet water temperature of 38°C, a water velocity of 2.06 m/s, and the boundary conditions of Fig.2, the simulated temperature distributions within the copper stove when water is flowing through channel are shown in Fig.5. The shell temperature at bottom of the stove is higher than that at the top. This is attributable to the gradually decreasing thickness of the packing materials from top to bottom. Table 2 shows the calculated water temperature at each channel exit. The water temperature difference in the center and wall channel respectively is 7.2°C and 7.7°C at a gas temperature of 1200°C. However, the water temperature difference at the channel exits is only about 0.5°C. This minor temperature discrepancy means that the stove design and the channel layout are correct.

The thermocouple shown in Fig.5 was installed in the copper body of No. 2 BF stove to monitor the stove status during the operation of the blast furnace. In this case, the calculated body temperature was 121.7°C, and the containing shell average temperature was 81.6°C.

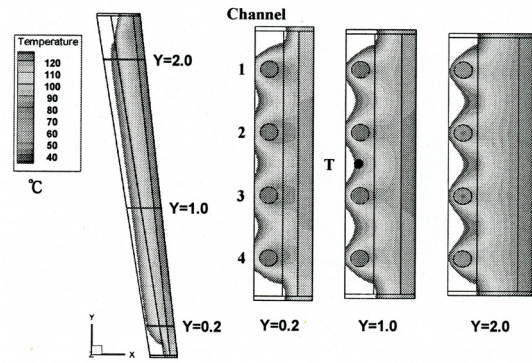

**Fig.5.** Temperature distributions of in a copper stove during water flowing through channel.

In order to explore the effect of various hot gas temperatures, five cases with 400, 800, 1200, 1600, 2000 °C were simulated and are shown in Fig.6. As the hot gas temperature increases, the body and shell temperatures are collaterally linearly increasing. Besides, the simulated result estimated that the shell temperature which has the lowest operation standard with 200°C even when the hot gas temperature reaches 2000°C was only 136°C. Compared with the measured data from the copper stove, with label S9-33, at No. 2 BF during stable operation the hot gas temperature was inferred to be about 400°C.

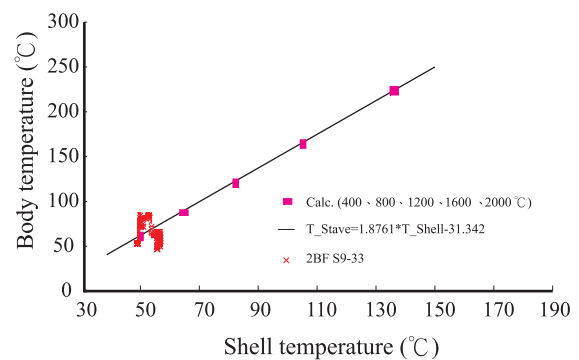

**Fig.6.** Relationship between body and shell temperature.

**Table 2** Water temperature at each channel's exit

Channel	1	2	3	4
Water temperature at exit (°C)	45.7	45.2	45.2	45.7

4.2 Copper stave with flexible pipe

Figure 7 shows the shell temperature distributions in differently-arranged flexible pipes at a hot gas temperature of 400°C and a water velocity of 3.51 m/s. It is apparent that the shell temperature in the case of a flexible pipe is higher than that in the channel case. When three or four channels are replaced by flexible pipes, the shell temperature will be higher than 200°C. This means that a defective copper stave with more than two flexible pipes needs other methods to reduce the shell temperature to extend its life. Besides, the shell temperature at the bottom of the four flexible pipes is higher than that at their top. It can also be induced that the thickness of packing material from top to bottom is gradually decreasing.

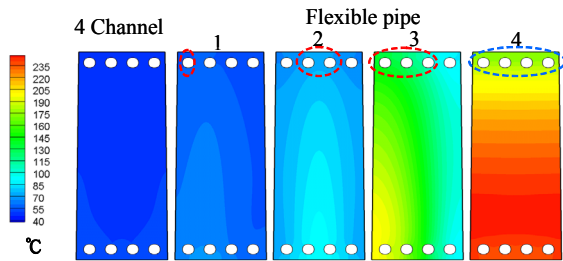

Fig.7. Shell temperature distribution with different flexible pipe arrangements.

To understand the effect of the hot gas temperature on differently-arranged flexible pipes, three cases with 400, 800, and 1200°C were simulated and are shown in Fig.8. All the cases, including that with 4 channels, and those staves with 1, 2, 3 and 4 flexible pipes, show that the body and shell temperature are linearly increasing with the hot gas temperature. The slopes in the cases of staves with 3 and 4 flexible pipes are steeper than the stave with 4 channels: this means that the hot gas temperature is sensible to the shell temperature. The average

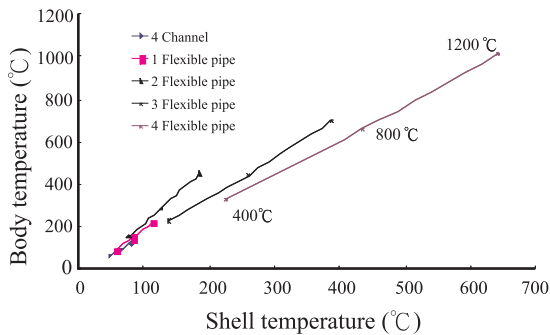

Fig.8. Relationship between body and shell temperature for different flexible pipes.

shell temperature in the case of the 4 flexible pipes is 225°C as the hot gas temperature reaches 400°C. This result shows that the cooling ability of 4 flexible pipes is not sufficient at No. 2 BF during stable operation.

In the following paragraph, two conditions comprising 4 flexible pipes and 4 plugs with two grouting materials of thermal conductivity 1.5 and 15 W/m°C, will be studied. Figure 9 shows the relationship between the shell temperature and the hot gas temperature. The shell temperature of the 4 flexible pipes with high thermal conductivity is lower than that flexible pipe with a low thermal conductivity. The reason is that the water in flexible pipe with higher thermal conductivity more easily takes away the heat of copper. Therefore, a grouting material with a high thermal conductivity is preferred and suggested for No. 2 BF. Besides, the shell temperatures in the cases of 4 plugs are almost the same regardless of whether the thermal conductivity is high or low. The shell temperatures is 280°C at a hot gas temperature 400°C. This result shows that the shell temperature is too high after the 4 flexible pipes are plugged.

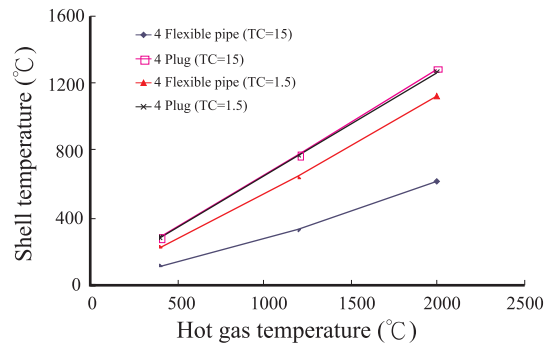
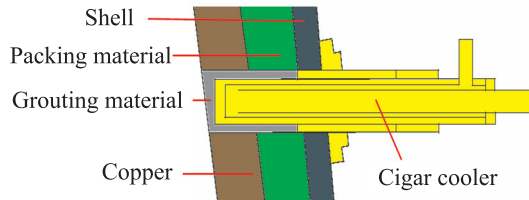

Fig.9. Relationship between shell temperature and hot gas temperature in the 4 plug case.

4.3 Copper stave with cigar cooler

Figure 10 shows that a cigar cooler inserted into a copper stave with the gap between them filled with a grouting material. To understand the heat transfer effect of the grouting material, three kinds of thermal conductivity have been simulated. Based on the cigar cooler with a water velocity of 1.7 m/s, a hot gas temperature of 1200°C, and the boundary conditions of Fig.4, the temperature distributions within the copper stave with a cigar cooler inserted are shown in Fig.11. The larger the thermal conductivity of the grouting material is, the lower the copper and shell temperatures are. The reason is that the water in the cigar cooler with higher thermal

conductivity more easily takes away the heat of the copper. Therefore, the cigar cooler with high thermal conductivity is preferred and suggested for No. 2 BF.



**Fig.10.** A cigar cooler in a copper stave.

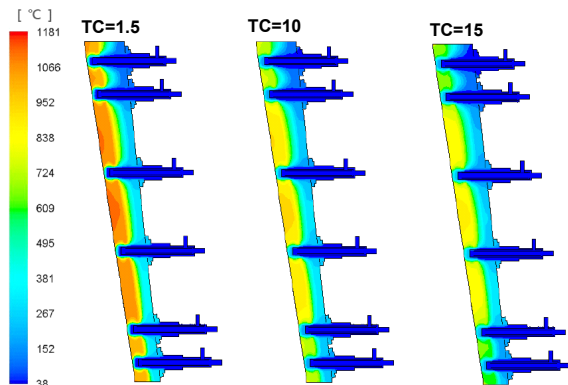

**Fig.11.** Temperature distributions of copper stave with cigar cooler.

Figure 12 shows the relationship between the shell temperature and the hot gas temperature for a copper stave with 24 cigar coolers. The shell temperature decreases from 127 to 107 to 100°C at a hot gas temperature of 400°C, when the thermal conductivity of the grouting material is increased from 1.5 to 10 to 15 W/m<sup>2</sup>/°C. This means that the defective copper stave after repair with 24 cigar coolers is acceptable during stable operation. However, the shell temperature with cigar cooler is higher than 200°C, whatever grouting material is used, when the hot gas temperature is 1200°C. This result indicates that the cooling ability of a defective copper stave with 24 cigar coolers is less than a normal copper stave with channel. Therefore, to control the hot gas temperature becomes very critical in protecting the furnace shell using a copper stave with 24 cigar coolers.

## 5. CONCLUSIONS

In this study, the heat transfer behavior of a defective copper stave installed with a flexible pipe or with a

cigar cooler has been analyzed and the calculated results can be summarized below:

- (1) Compared with measured data from copper stave with label S9-33 at No. 2 BF during stable operation, the hot gas temperature is inferred at about 400°C.

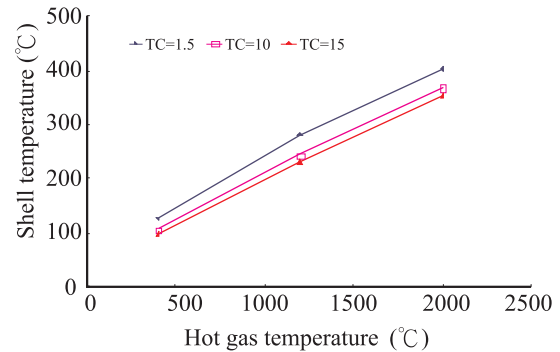

**Fig.12.** Relationship between shell temperature and hot gas temperature of a cigar cooler.

- (2) The cooling ability of 4 flexible pipes with low thermal conductivity 1.5 W/m<sup>2</sup>/°C is not sufficient during stable operation. A grouting material with a high thermal conductivity of 15 W/m<sup>2</sup>/°C is preferred and suggested for No. 2 BF.
- (3) The defective copper stave with 24 cigar coolers is acceptable during stable operation. However, using staves equipped with cigar coolers, the shell temperature is higher than 200°C with any kind of grouting material, when the hot gas temperature is 1200°C. Thus, to control the hot gas temperature becomes very important to protect the furnace shell when a copper stave with 24 cigar coolers is installed.

## REFERENCES

1. P. Heinrich, H. J. Bachhofen and W. Kowaiski, *Iron and Steel Engineer*, (1992), p.49.
2. S. S. Cheng, T. J. Yang and D. Q. Cang, *J. Iron & Steel Res., Int.*, 10 (2003), p.1.
3. Z. Qian, L. J. Wu, H. E. Cheng and K. Deng, *Iron and Steel*, 40 (2005), p.21.
4. L. Qian and S. S. Cheng, *Journal of University of Science and Technology Beijing*, 28 (2006), p.1052.
5. S. S. Cheng, L. Qian and H. B. Zhao, *Journal of Iron and Steel Research, International*, 14 (2007), p.1.
6. C. P. Yeh, C. K. Ho and R. J. Yang, *International Communications in Heat and Mass Transfer*, 39 (2012), p.58. □